

EFFECT OF EQUAL CHANNEL ANGULAR PRESSING (ECAP) ON MECHANICAL PROPERTIES AND WEAR BEHAVIOR OF AL-7075 ALLOY

Heba K., El-Abden S. Z., Mazen A. A.

Production Engineering and Mechanical Design Dept., Faculty of Engineering,
Minia University, EGYPT.

ABSTRACT

Equal-channel angular pressing is one of the best procedures for introducing an ultrafine grain size into a material. By using samples of pure Al, 7075 Al and 2021 Al as received and after annealing, by passing them through channel angle Θ , channel angle Θ is intersection of the two channels within the die on the subsequent. Experiments were performed using dies having channel angles from 110° to 135° . dry sliding wear tests have been conducted using a pin-on-disk machine under different loads of 10, 20 and 30N at a constant sliding speed of 2 m/s. Comparison of strength and wear resistance of specimens shows that by using ECAP process, strength and wear resistance of the specimens increase considerably due to the formation of very fine grains during ECAP.

KEYWORDS

Aluminum alloys, SPD, equal channel angular pressing (ECAP), finite element analysis, wear rate, mechanical property and aluminum alloy.

INTRODUCTION

In recent years, Ultrafine-grained (UFG) materials processed by severe plastic deformation (SPD) have attracted growing interest in the area of materials science. These superior properties distinguish UFG materials from their coarsegrained counterparts. Among all the SPD techniques, equal channel angular pressing (ECAP) is especially attractive because there is a potential to scale-up the technique for industrial applications. The ECAP behavior was determined using three different processing routes A (orientation of the specimen remains unchanged after each pass), Bc (Route B is when the specimen is rotated 90° around its longitudinal axis after each pass if the rotation direction is alternated between counter clockwise and clockwise, it is called route Bc) and C (180° rotation around longitudinal axis after each pass) with four passes undergoes on AlMg3 alloy at the angle between the channels was 120° . The results showed that the processing route has a significant impact on grain size and hardness so that the grain size for AlMg3 alloy before ECAP has an average grain size about $330 \mu\text{m}$ and after ECAP process as it grain size is decreasing. as it could be seen there is large increase in hardness for all ECAP processing routes about 95% in comparison to before

ECAP. It was observed that the highest grain refinement and hardness was achieved for route Bc, [1]. The effect of an integrated extrusion and equal channel angular pressing (IEECAP) was calculated, [2], at 350°C, 3 mm/s speed, and 90° angle of the IEECAP die with one pass on Mg-Nd-Zn-Zr alloy. Microstructural observations showed a significant refinement of grain structure after a single pass extrusion. The average grain size was reduced to around 0.5 μm. Magnesium samples were processed through ECAP by following three different routes (i.e. the A, Bc, and C routes) for one, two, four, and eight passes respectively performed the ECAP processing of pure aluminum using the molds with the channel angles of 90°, 112.5°, 135°, and 157.5°. The results were for the three routes, the increase of the number of ECAP passes generally led to more uniformly refined microstructure. Bc and C routes can refine the microstructure of magnesium more efficiently than A route. Among the three studied routes, Bc route achieved the most homogeneous microstructure with uniformly distributed twins, while both A and C routes resulted in heterogeneous microstructure. The optimum processing parameters (i.e. channel angle, corner angle and friction coefficient) by using finite element modeling for ECAP were investigated, [3], in order to design the die correctly. Results showed that this parameters have significant influences on deformation behavior, strain coefficient of variance and punch load evolution and it is found that the optimum parameters for maximum strain homogeneity correspond to channel angle $\phi = 90^\circ$, corner angle $\psi = 15^\circ$ and friction coefficient $\mu = 0.3$, [4]. Microstructure, texture, and mechanical properties of magnesium alloy processed by ECAP using a die with an angle of 120° between the channels by using processing route BC were investigated. investigations showed that the grain refinement down to 0.7–1 μm and increased strength and ductility, [5]. The Processing of A Cu-Mg-Ca alloy was studied by equal channel angular pressing (ECAP) process up to 12 passes via Bc route at room temperature using a die with the angle of 110° between the two channels and with an additional outer arc of curvature of 30°, [6]. It was concluded that, the Cu-Mg-Ca alloy after 12 ECAP passes showed excellent comprehensive properties Compared with the Cu-Mg alloy under the same condition, the yield strength of the designed alloy after 12 ECAP passes was improved by 30 MPa and the electrical conductivity increased by 0.63 % IACS. The present work gives continuity to the above-mentioned researches by investigating the influence of ECAP processing parameters on pure aluminum, Al-2021 and Al-7075 alloys. Such materials were investigated under two parameters (channel angle and material conditions). That parameter affected on strength, and wear rate of testing materials.

EXPERIMENTAL

Materials and Methods

The aluminum and aluminum alloy can be considered the most popular materials used during ECAP process. The Al-Cu alloys consider the one of the most important Al alloys used in the aircraft industries. Aluminum alloys have strong corrosion resistance. At subzero temperatures, their strength increases thus they are useful at low-temperature applications. Their strength decreases if they are subjected to very high temperatures. The aluminum 7075 alloy has high strength. The following datasheet gives more details about the aluminum 7075 alloy.

Chemical Composition

Table 1 shows the chemical composition of the aluminum 7075, 2021 alloy. The brief overview of the experimental procedures is shown schematically in Fig. 1. Before ECAP process, the initial material was cut into small pieces and then heat treated to measure the grain size by optical microscopy. Also, compression tests, wear test and microhardness test were performed in order to compare with data obtained after ECAP process.

Design and manufacturing of die

In principle, three types of dies were used for ECA pressing. The main operating mechanisms for the three dies are identical: The two channels were drilled in a bulk piece of steel. The three dies have angles of 110° , 120° and 135° . The first die has two channels with an internal angle of $\Phi = 110^\circ$ and an outer angle at the intersection of the two channels of $\Psi = 110^\circ$. The second die has two channels with an internal angle of $\Phi = 120^\circ$ and an outer angle at the intersection of the two channels of $\Psi = 120^\circ$, while the third die has two channels with an internal angle of $\Phi = 135^\circ$ and an outer angle at the intersection of the two channels of $\Psi = 135^\circ$. The tolerance of the plunger was kept extremely low to prevent materials from flowing in between the walls of the channel and the plunger. The ECAP dies and Plunger are shown in Figs. 2 - 5.

Table1 Chemical Composition of commercial 7075 Aluminum alloy.

Element	Content (%)
Aluminum, Al	90
Zinc, Zn	5.6
Magnesium, Mg	2.5
Copper, Cu	1.6
Chromium, Cr	0.2

Table 2 Chemical composition of the aluminum 2021 alloy.

Element	Content (%)
Aluminum, Al	90.4299 — 93.6399
Copper, Cu	5.8 — 6.8
Tin, Sn	0.03 — 0.8
Magnesium, Mn	0.2 — 0.4
Iron, Fe	0.3
Silicon, Si	0.2 — 0.3
Zirconium, Zr	0.01 — 0.25
cadmium, Cd	0.05 — 0.2
Vanadium, V	0.05 — 0.15
Zinc, Zn	0.1
Titanium, Ti	0.02 — 0.1
Magnesium, Mg	0.02

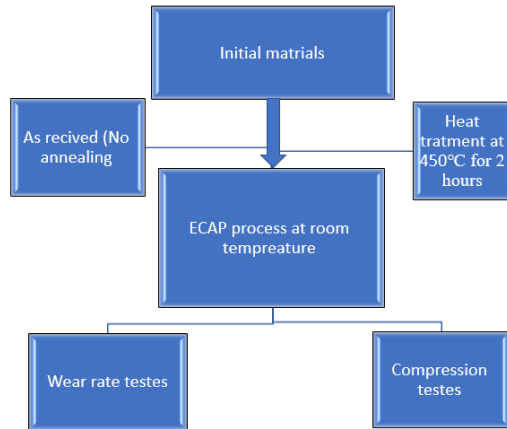

Fig. 1 Flow chart of the experimental procedures.

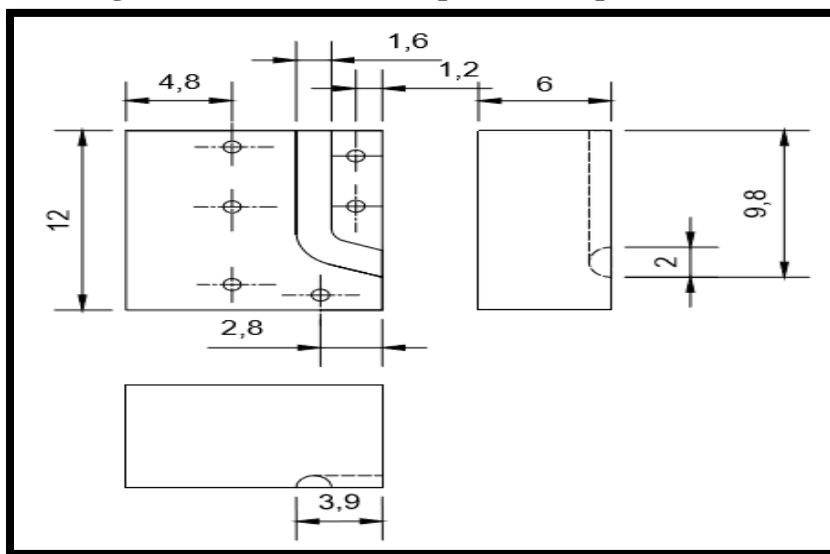

Fig. 2 The die for ECAP process at $\Psi = 110^\circ$.

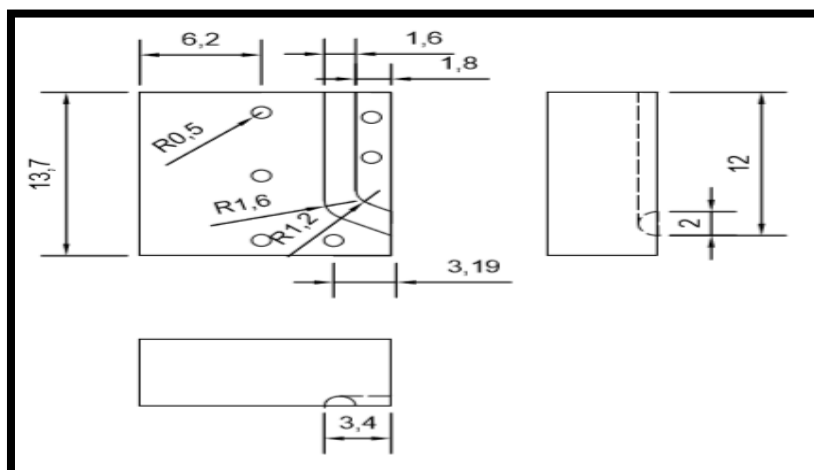

Fig. 3 The die for ECAP process at $\Psi = 120^\circ$.

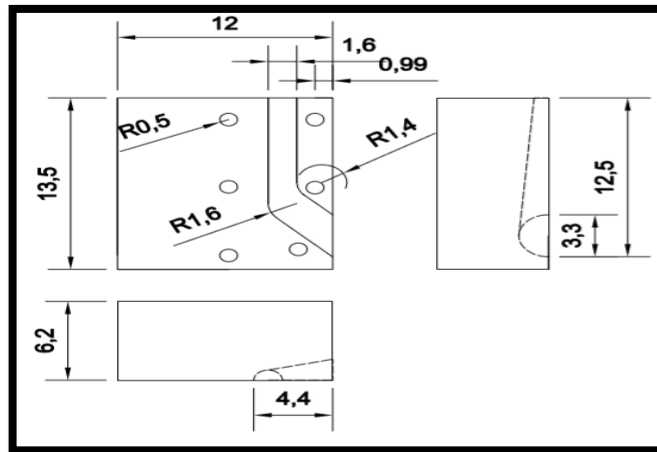

Fig. 4 The die for ECAP process at $\Psi = 135^\circ$.

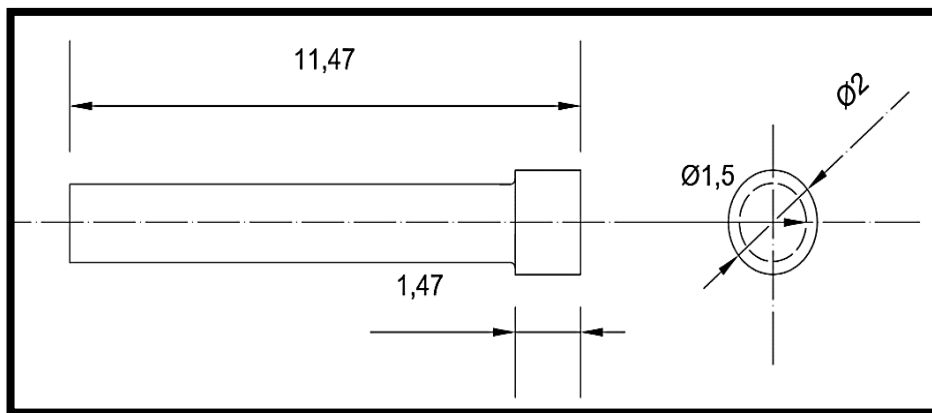

Fig. 5 The plunger for ECAP process.

2.4 The ECAP specimens dimensions

The specimen before and after ECAP is shown in Figs. 6 and 7.

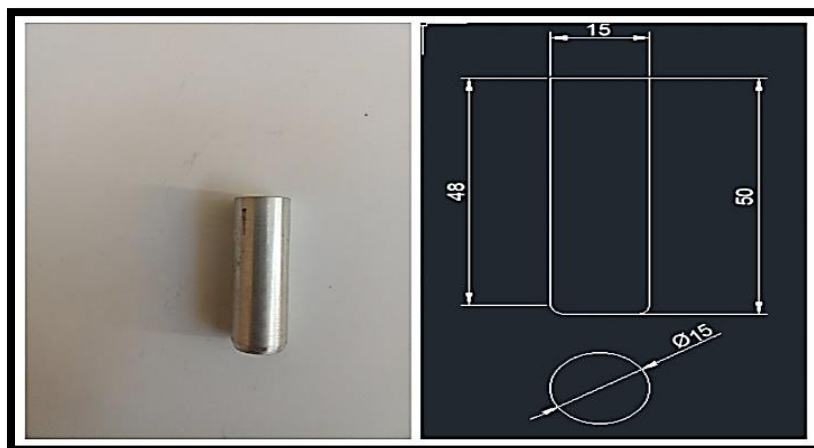

Fig. 6 The specimen before ECAP.



Figure. 7 The specimen after ECAP.

2.5 Procedure for ECAP processing

The ECA pressing facility was set up using a universal machine test having a 30 tons capacity. The press mainly consists of two plates: the upper plate is moving and the lower plate is moving. The ram speed of the press is about 10 mm/sec. As an initial step, the die was fixed firmly on the bottom plate. Before pressing, the billets and plunger were well lubricated by Shell Gadus S2 V220AC 2(High-performance, water-resistant, extreme-pressure grease). The some billets were annealed at a temperature of 450°C for 2 h and then cooled to room temperature before processing by ECAP. Then the die and the plunger were aligned perfectly to avoid bending of the plunger during the pressing. The next step , compression the samples by universal machine test.

MECHANICAL TESTING (Compression Testing)

In order to investigate the mechanical behavior, compression experiments were conducted on the samples in the as-received condition, and after processing. For ECAP samples, thereafter, compression specimens were prepared from the disks in each condition.

Specimen configuration

The compression samples have a dimension of 12 mm in diameter and 11 mm in length. The dimension of compression specimens is presented in Fig. 8.

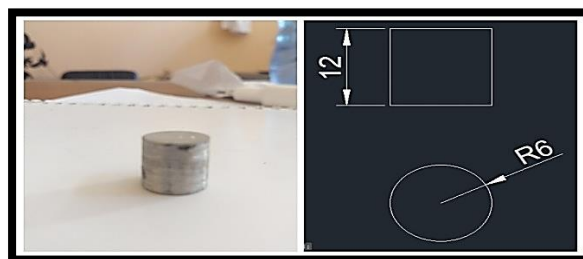

Fig. 8 compression test specimen.

Compression testing

A compression test is any test in which a material experiences opposing forces that push inward upon the specimen from opposite sides or is otherwise compressed, “squashed”, crushed, or flattened. The test sample is generally placed in between two plates that distribute the applied load across the entire surface area of two opposite faces of the test

sample and then the plates are pushed together by a universal test machine fig (3-9) causing the sample to flatten. A compressed sample is usually shortened in the direction of the applied forces and expands in the direction perpendicular to the force. A compression test is essentially the opposite of the more common tension test. By testing a material in compression, the compressive strength, yield strength, ultimate strength, elastic limit, and the elastic modulus among other parameters may all be determined.

Tribological Properties (Wear Behavior)

Pin-On-Disk (POD) tests were designed to follow ASTM Standard G99. The test consisted of holding an ECAE processed specimen against a rotating disc on which a square shape steel disk is mounted. Wear tests were conducted at different normal loads of 2, 6 and 10 N with constant sliding speed of $N = 160$ rpm ($\omega = 16.755$ rad/s) ($v = 2$ m/s). Wear tests were done on dry sliding condition (no lubricant). Before the tests, the ECAE processed specimens were machined to cylindrical shape of diameter 11 mm. The samples were thoroughly cleaned with an organic solvent to remove surface contaminants before and after each test. Weight loss after the test was measured for each sample. During the tests, the coefficient of friction was determined. Strain gages were mounted to the arm holding the pin (specimen) to measure the friction load during wear testing. the friction force was measured by taking the average friction force per 30 sec. The coefficient of friction (μ) was then calculated as:

$$\mu = \frac{\text{Friction force} \times 10}{\text{Normal force}} = F_f / F_n,$$

The wear was calculated by the difference before and after test. The worn surfaces were examined using optical microscope.

RESULTS AND DISCUSSION

Mechanical properties (Compression test)

Compression tests were performed on as-received pure aluminum before and after ECAP. The typical stress-strain curves for this material indicated that, the stress decreases with increasing the angle of deformation of ECAP process. The results also showed that, under the same testing condition, the ECAP process material has a greater yield stress while the material before ECAP process displayed smaller yield stress as shown in Fig. 6. As for heat treated pure aluminum before and after ECAP at 450°C, the stress decreases with increasing the angle of deformation of ECAP process. Under the same testing condition, the ECAP process material has a greater yield stress while the material before ECAP process a smaller yield stress.

As-received aluminum 7075 alloy before and after ECAP showed that, the stress decreases with increasing the angle of deformation of ECAP process. The same trend was observed for heat treatment aluminum 7075 alloy before and after ECAP at 450°C and heat treatment aluminum 2021 alloy before and after ECAP at 450°C.

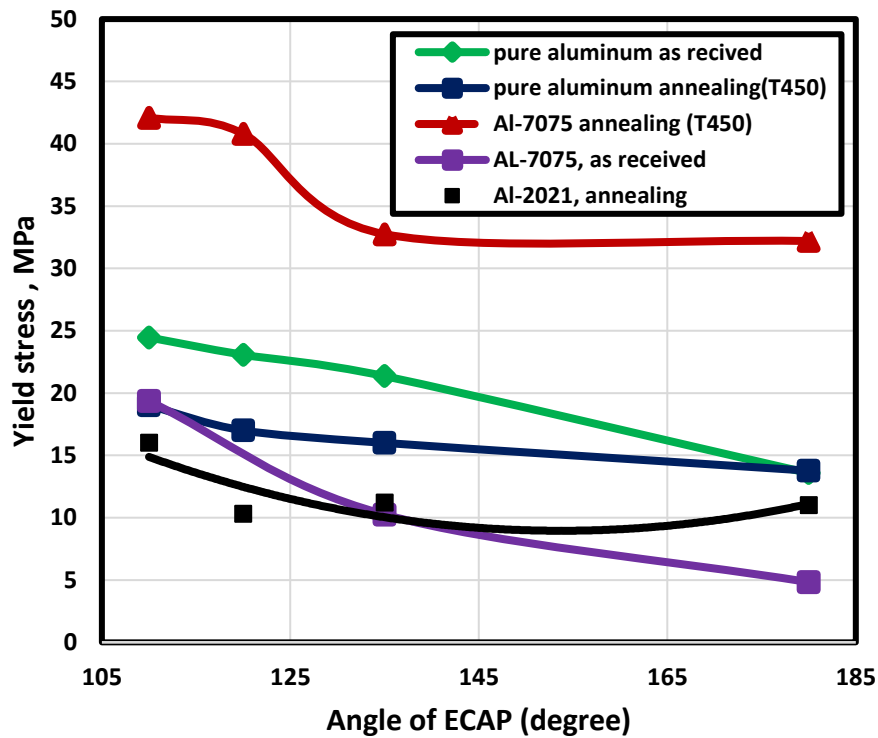

Fig. 6 Graphical representation of the variation in angles as a function of yield stress in ultra-fine grained materials.

2. Tribological Properties (Wear Behavior)

Figures 7, 8 show the effect of applied load and ECAP process on the wear during wear test of Al-7075 and Al 2021 at 474 m sliding distance. The figure shows that the wear was reduced with decreasing the angle of ECAP process and increased with decreasing of applied load of wear test. This reduction in the wear value after ECAP process can be attributed to the grain refinement and the increase in the strength. Figure 9 shows the effect of type of material and ECAP process on the wear under the load of 2 N. The figure shows that the wear amount of wear of pure aluminum is higher than that observed for Al 7075. The wear reduction of Al 7075 can be attributed to its very good properties such as good hardness and strength which is caused by increasing Mg content (see Table 1 and Table 2).

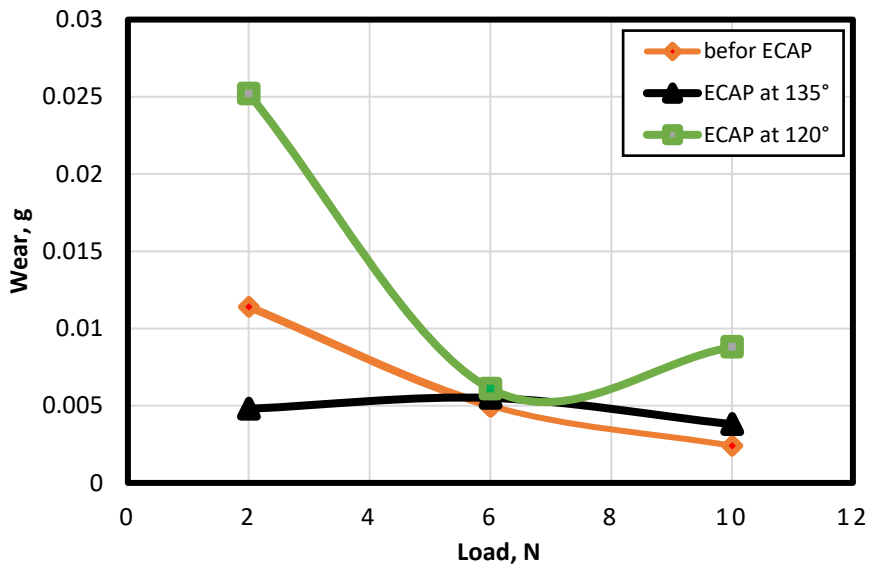

Fig. 7 Effect of angle of ECAP and applied load on the wear of Al-7075.

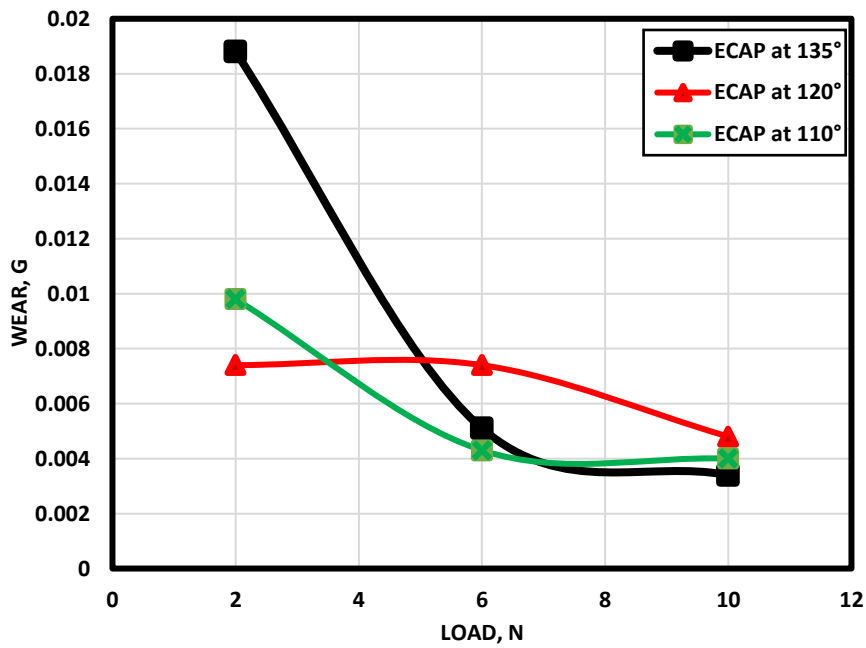

Fig. 8 Effect of angle of ECAP and applied load on the wear of Al-2021.

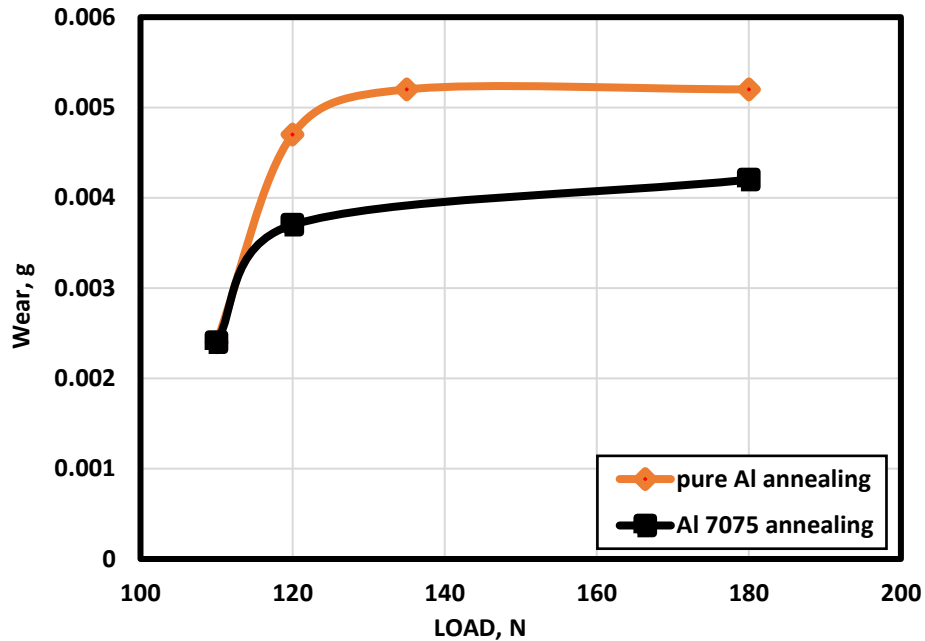

Fig. 8 Effect of type of material and applied load on the wear.

CONCLUSIONS

In this paper, the mechanical and the wear properties of pure aluminum, Al 7075 and Al 2021 alloy processed by ECAP were investigated. The following conclusions based on the experimental results can be drawn:

1. Wear resistance of pure aluminum, Al 7075 and Al 2021 alloy were improved significantly by refining the grain size of the alloy during ECAP process.
2. Corrosion wear of pure aluminum is higher than in Al 7075 and Al 2021.
3. The ECAP processed material has a greater offset stress while the material before ECAP process a smaller offset stress.

REFERENCES

1. Tański T., et al., "Influence of processing routes on structure and residual stress in aluminium-magnesium alloy after ECAP", *Journal of Achievements in Materials and Manufacturing Engineering*, 63 (1), pp. 5 - 12,(2014).
2. Zhao S., et al., "Microstructure and mechanical properties of Mg-Nd-Zn-Zr alloy processed by integrated extrusion and equal channel angular pressing", *Journal of Alloys and Compounds*, 705, pp. 118 - 125, (2017).
3. Li Q. and X. Jiao, "Exploration of equal channel angular pressing routes for efficiently achieving ultrafine microstructure in magnesium", *Materials Science and Engineering: A*, 733, pp. 179 - 189, (2018).
4. Agwa, M.A., M.N. Ali, and A.E. Al-Shorbagy, Optimum processing parameters for equal channel angular pressing. *Mechanics of Materials*, 100, pp. 1 - 11, (2016).
5. Martynenko N., et al., Increasing strength and ductility of magnesium alloy WE43 by equal-channel angular pressing. *Materials Science and Engineering: A*, 712, pp. 625 - 629, (2018).
6. Ma M., et al., Microstructure and properties of Cu–Mg–Ca alloy processed by equal channel angular pressing. *Journal of Alloys and Compounds*, 788, pp. 50 - 60, (2019).