

EFFECT OF MAGNETIC FIELD ON FRICTION AND WEAR OF BRASS

Abeer A. E.¹, Abu Elainin H. M.¹, Khashaba M. I.¹ and Ali W. Y.^{1,2}

¹Faculty of Engineering, El-Minia University, P. N. 61111, El-Minia, EGYPT.

²Present Address: Faculty of Engineering, Taif University, P. N. 888, Al-Taif, K. S. A.

ABSTRACT

The present work discusses the effect of the magnetic field on the friction and wear of brass sheets scratched by a steel insert at dry and lubricated by vegetable oils and dispersed by polymeric particles such as polyethylene (PE), polyamide (PA6) and polymethylmethacrylate (PMMA).

Experimental results showed that, friction coefficient at dry and oil lubricated brass surface displayed higher values than that observed for steel. As the magnetic field is applied, friction coefficient drastically decreased. Polymeric particles caused significant reduction in friction coefficient. Application of the magnetic field showed further friction decrease. Under the action of the magnetic field, friction coefficient slightly decreased for dry and oil lubricated sliding. Castor, almonds, camomile, jasmine, maize, and olive oils displayed lower friction.

Wear displayed relatively higher values than that observed for steel. Camomile and almonds oils showed the lowest wear values. Application of the magnetic field slightly decreased wear. Olive, jasmine and maize oils displayed the lowest wear values. Presence of polymeric particles on the sliding surfaces slightly decreased wear. Magnetic field showed wear decrease. Dry sliding displayed relatively lower values of wear. Castor and maize oils showed good wear resistance.

KEYWORDS

Friction, wear, brass, magnetic field.

INTRODUCTION

Presence of electric current and magnetic field around the tribocontact modified the mechanical properties of the surface and subsurface, [1]. The mean friction coefficient changed from 0.16 without electric current and magnetic field to 0.26 with them, and its variation reduces considerably. The worn surfaces were smoother with magnetic field application than that without it, and the modification of subsurface structure was observed. The magnetic field and the electric current modified the mechanical and chemical properties of this ferromagnetic material in the sliding contact by interaction with cyclic contact stresses

and increasing the temperature on the contact surface. This interaction was characterized by an increase of the microhardness, the activation of oxidation on the surfaces, the difference of contact noise level and the changes induced in subsurface structure.

Magnetostriction or deformation of material took place during the application of the magnetic field, [2]. An electric current crossing a sliding couple affects the surface temperature, the oxidation and the contact behavior. The magneto-tribological interaction of materials was investigated particularly for braking and cutting tools to increase their lifetime and to improve the surface quality after machining, [3]. It has been observed that the friction behavior of ferromagnetic and non-ferromagnetic metals was modified in the presence of a DC magnetic field. The effects induced by a simultaneous application of a DC electric current and an AC magnetic field on the surface and subsurface modifications of the ferromagnetic contact couple steel/steel were presented.

The effects of external electric fields on frictional behaviors of Al_2O_3 /brass, Al_2O_3 /stainless steel and Al_2O_3 /carbon steel couples under boundary lubricating conditions were studied on a self-made plate/plate type tribotester, [4]. Results acquired from experiments carried out in a wide range of external voltage, from 0 to 110 V, indicating that friction coefficient of Al_2O_3 /brass couple increases monotonously with the intensity of the external electric field, although no linear relationship was found between them. It was found that friction and wear were attributed to the migration of electrons across the interfaces of metals with different work functions. It was found that the difference in the orientations of function groups of polymers under different electric fields influences the intensity and the direction of interfacial forces between polymer and metal surfaces, [5]. The apparent friction coefficient was changed by reversing the polarity of the external electric field due to the change in real normal pressure. An extraordinary change in friction coefficient of graphite/graphite rubbing couples was discovered, [6], under a large DC current at a critical sliding speed, jumping from a high value (about 0.7) to a low value (about 0.07) as rubbing slows down or from the low value to the high value as rubbing speeds up. It was found that for intentionally insulated metallic contacts lubricated with liquid crystals the relative friction coefficient under boundary lubrication conditions can be reduced by up to 35% by applying an external DC electric field, [7]. DC voltages were found to be able to promote the generation of chemisorbed and chemical reaction films of ZDTP additives in mineral lubricating oils on metal surfaces, leading to a reduction in friction, [8, 9]. It was reported that an AC voltage has effects on lubricating ability of synovia constituents, [10]. It was observed that for Al_2O_3 /brass couple lubricated with emulsion of zinc stearate the change in friction coefficient due to an external DC voltage is not only remarkable, reaching 200 %, but also quick and reversible, [11]. Besides, friction coefficient of Al_2O_3 /brass couple increased monotonously with increasing external electric field intensity in the range of 0 - 30 DCV, [12], and that the fastest increase of friction coefficient occurs within the range of 0 - 20 DCV.

The effect of an applied electric field on the running-in operation of a roller bearing was investigated, [13, 14]. In the mixed lubrication regime, when the bearing was the anode, the friction coefficient increased and also the bearing temperature increased and showed signs of seizure. The bearing surface was oxidized as would be expected, because of an anodic reaction. However, when the bearing was cathode, the friction coefficient rapidly decreased

and so did the bearing temperature. The effect of additives in highly refined paraffinic base stocks on wear under the influence of an electric current was also investigated, [15, 16]. The addition of sulfur compound decreased wear on the cathodic surface, while wear was increased on the anodic surface.

It was found that an externally applied voltage may modify the wear behaviour of the lubricant and also, without friction, its decomposition and its reactivity on the surface, [17]. Because of triboelectrification, the charged surfaces can interact with each other due to the direct electrostatic forces, [18]. Since these forces are strong and effective, they contribute a major part of the adhesion force.

Friction of polymers is accompanied by electrification. The basic mechanism of solid triboelectrification implies processes, which can be described in terms of surface conditions. During frictional interaction chemical and physicochemical transformations in polymers promote increases in the surface and bulk states density, [19]. Ionization and relaxation of those states lead to electric fields of the surface and bulk charges. Electrification in friction is a common feature, it can be observed with any mode of friction, and with any combination of contacting surfaces.

The potential difference generated by the friction of polymeric coatings against steel counterface has been measured. The effect of sliding velocity and load on the generation of electric charge on the friction surface has been investigated, [20]. The results indicate that, at dry sliding condition the potential generated from friction increases rapidly with increasing both of sliding velocity and load at certain values then decreases due to the rise of temperature which causes molecular motion and reorientation of the dipole groups in the friction direction and leads to the relaxation of space charges injected during friction. Presence of water or oil on the friction surface, oil impregnation of polyamide coating and filling polyamide by molybdenum disulphide reduce the potential difference while filling the coatings by graphite increases that potential. The electrification of polymer surface can be controlled by using composites of different polymers.

The triboemission characteristics of both negatively and positively charged particles from various materials such as metals, ceramics and glass were studied, [21]. The results obtained during scratching the tested materials showed increasing emission intensity with increasing electrical resistance of the materials. Friction and dielectric measurements performed on sapphire and alumina samples were correlated, [22]. Mechanisms of polarization and relaxation of dielectrics were used to provide explanation of the friction and wear behaviour of insulators.

Experiments were carried out to investigate the influence of the applied voltage on the friction and wear of polymeric coatings sliding against steel. Unfilled and filled PA 6 coatings by metal powders as well as high density PE, PA 6, polypropylene coatings, reinforced by copper wire, were tested. Increasing the concentration of metal powder can reduce the effect of the applied voltage on friction and wear. Reinforcing PA 6 and polypropylene coatings by copper wires increased the wear resistance and reduced the friction, [23]. This improvement may be

attributed to the strengthening effect of the copper wire and its ability to leak some of the electric charge formed on the friction surface.

By applying an electric field between the rubbing surfaces, the oxidation of the rubbing surface at anode side is enhanced, and suppressed on the cathode side surface. The oxide film formed on the anode surface being harder than the bulk steel, the rubbing surface at the anode side was little worn, but it at cathode side was abrasively worn considerably. The application of an electric field, however, is considered to promote the breakdown of EHL film formed. Therefore, the effect of the application of an electric condition tested, [24, 25]. The influence of applying electric field on the tribological behaviour of steel in a vertical magnetic field produced by an AC or DC electric current was investigated.

The rubbing process breaks up the polymer surface and liberates free radicals and ion radicals, [26]. These are highly reactive and react with oxygen dissolved in the lubricant. They are immediately transformed to peroxide and these react with the metal surface to form oxide films. These are disrupted by the sliding process and continuous oxidation and removal of oxide takes place. This leads to increased oxidative wear of the metal surface. Voltage generated as a result of the friction caused by the sliding of polymers against each other as well as steel surface was measured, [27]. The test results showed that friction coefficient displayed by the sliding in salt water represented maximum values due to the relatively high value of voltage generated as a result of friction.

Triboelectrification of metallic and polymeric surfaces was investigated at dry and lubricated sliding conditions, [28]. The maximum value of both friction and voltage were displayed by sliding of aluminum on bearing steel surface. Contaminating motor oil by ethylene glycol displayed the highest voltage followed by diesel fuel and gasoline for steel sliding on bearing steel. It was found that a correlation between friction coefficient and voltage generated was found for polymers sliding against PET and against steel in water and salt water lubricated conditions, [29]. Wear of the tested polymers decreased with increase of sand particle size down to minimum because of the sand embedment in the polymeric surface. Further increase in sand particle size increased wear due to the removal of sand from the polymeric surface.

The development and application of environmentally friendly lubricants is therefore a task for tribologists and lubrication engineers, [30, 31]. Most of the big petroleum companies have begun to search and develop environment friendly products. Vegetable oils are potential replacements of mineral oil base stocks because they usually have high biodegradability and low toxicity and their resources can be recycled, although the industrial applications of vegetable oils as green lubricating base stocks are still at an early stage.

In the present work, the effect of the magnetic field on the friction and wear of brass sheets scratched by steel insert at dry, lubricated by vegetable oils and dispersed by polymeric particles such as polyethylene (PE), polyamide (PA6) and polymethylmethacrylate (PMMA) is discussed.

EXPERIMENTAL

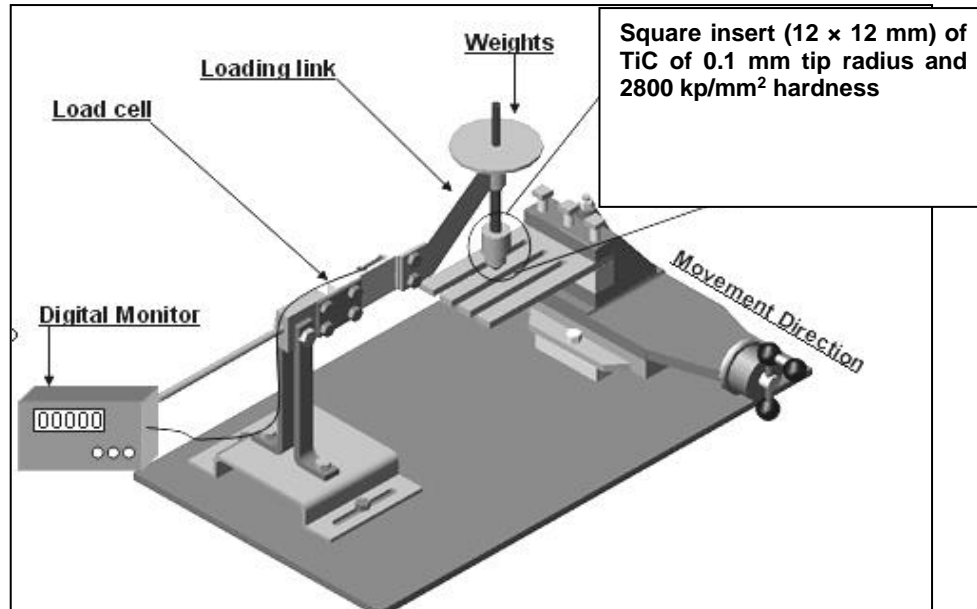

Fig. 1 The arrangement of the test rig.

The test rig, used in the experiments was top scratching tester equipped with an insert to produce a scratch on a flat surface with a single pass. The details of the test rig are shown in Fig. 1. The insert, used in experiments, was a square insert (12 × 12 mm) of TiC of tip radius of 0.1 mm and hardness of 2800 kp/mm². The scratch force was measured by the deflection of load cell. The ratio of the scratch force to the normal force was considered as friction coefficient. Wear was considered as the wear scar width of the scratched wear track. The width was measured by optical microscope with an accuracy of $\pm 1.0 \mu\text{m}$. The tested surface was ground by an emery paper (500 grade) before testing. The load was applied by weights. The test speed was nearly controlled by turning the power screw feeding the insert into the scratch direction that was adjusted to be 2 mm/s. The applied load values were 2, 4, 6, 8 and 10 N. All measurements were performed at $28 \pm 2^\circ \text{C}$ and $50 \pm 10\%$ humidity. The vegetable oils used in the experiments were castor, maize, olive, almonds, jasmine and camomile oils. The polymers used in the experiments were polyethylene (PE), polyamide (PA6) and polymethylmethacrylate (PMMA). Brass sheets of 100 mm long, 30 mm width and 1 mm thickness of 720 MPa Hardness were used as counterface.

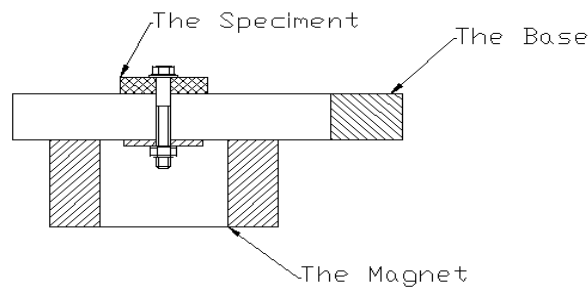

Fig. 2 The test specimen fixation.

The test specimens were fixed on the base and the magnet of 0.1 Mg (flux intensity) was assembled back to the test specimens, Fig 2. The tested materials were brass sheets of 100 mm long, 30 mm wide and 1.0 mm thickness. The mechanical properties are shown in Table 1.

Table 1 Mechanical properties of the brass test specimens.

Ultimate tensile strength	290 – 350 MPa
Hardness B. H. N	600 – 800 MPa
Surface roughness, R _a	3.8 μm

RESULTS AND DISCUSSION

Friction coefficient at dry and oil lubricated brass surface displayed higher values than that observed for steel, Figs. 2. 1 and 2. 2. This trend could be interpreted on the basis that the hardness of brass (72 MPa) is lower than the hardness of the steel (100 MPa). In this condition, the depth of the insert in the brass was relatively higher than the depth of the wear scar of the steel surface. Consequently, the volume of the material removed from the brass surface was relatively higher than that removed from the steel surface and the area of the insert exposed to the friction of the removed brass was relatively higher.

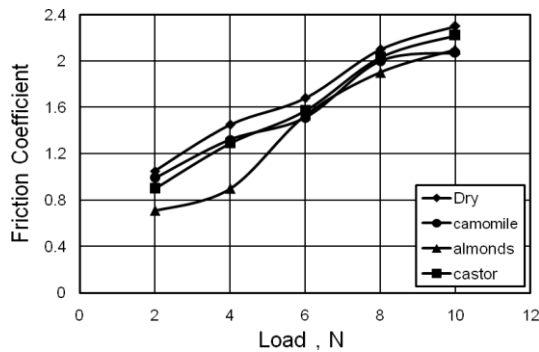

Fig. 2. 1 Friction coefficient at dry and oil lubricated brass surface.

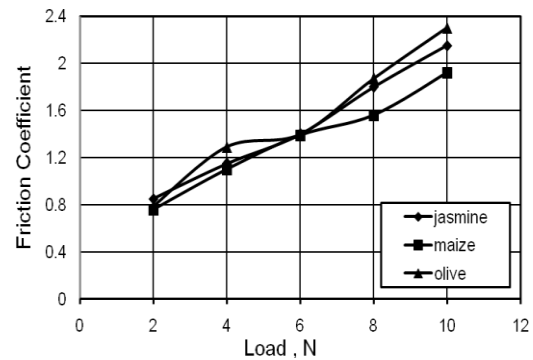

Fig. 2. 2 Friction coefficient at oil lubricated brass surface.

As the magnetic field was applied, friction coefficient drastically decreased, Figs. 2. 3 and 2. 4. This effect might be from the reorientation of the oil molecules on the surfaces of the insert as well as the brass. Generally, values of the friction coefficient displayed by the abrasion of brass were relatively higher than that observed for steel. Material transfer from the brass into the insert surface might be responsible for the friction increase. The ability of the adherence of brass in the insert edges was higher than that observed for steel. This could be explained on the basis of the electric static charge formed on the brass (negative charge) which strengthened the adhesion between brass and insert surface.

Contaminating the sliding surfaces by PE caused significant reduction in friction coefficient, Figs. 2. 5 and 2. 6. Adherence of the PE particles of negative electric charge into the sliding surfaces of positive charge decreased the abrasion action of insert into the brass surface.

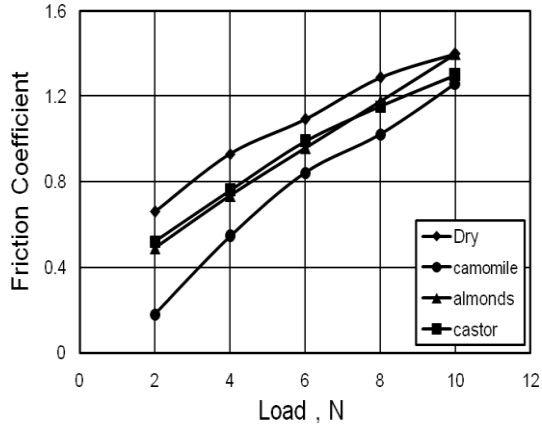

Fig. 2. 3 Friction coefficient at dry and oil lubricated brass surface under magnetic field.

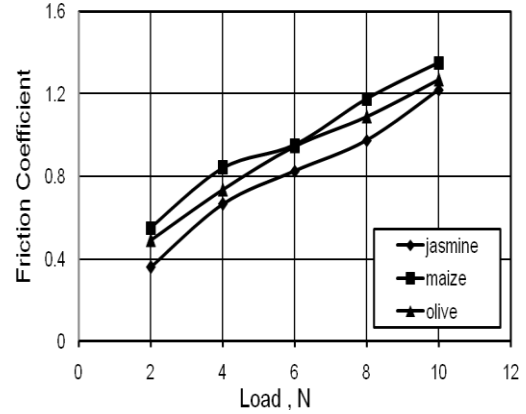

Fig. 2. 4 Friction coefficient at oil lubricated brass surface under magnetic field.

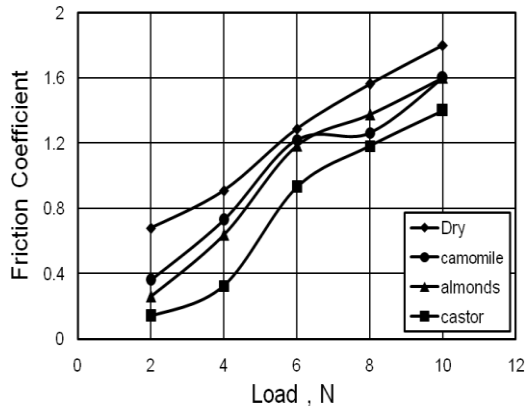

Fig. 2. 5 Friction coefficient at dry, oil lubricated and PE contaminated brass surface.

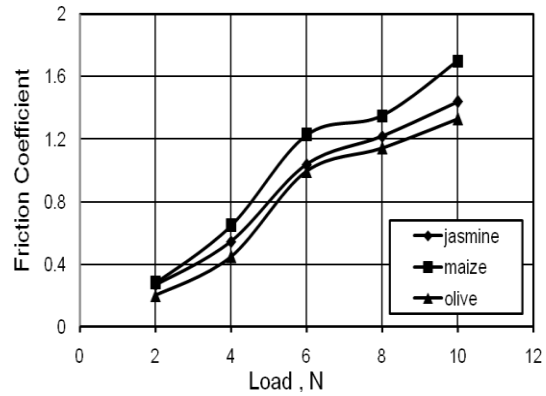

Fig. 2. 6 Friction coefficient at oil lubricated and PE contaminated brass surface.

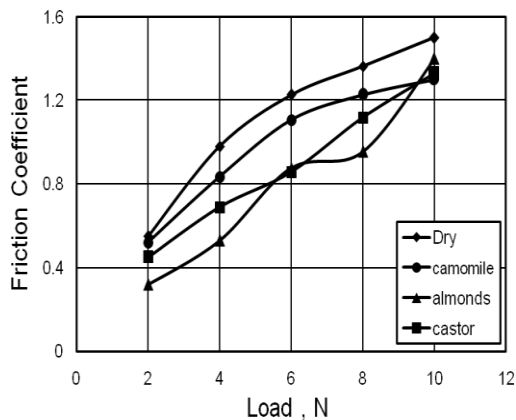

Fig. 2. 7 Friction coefficient at dry, oil lubricated and PE contaminated brass surface under application of magnetic field.

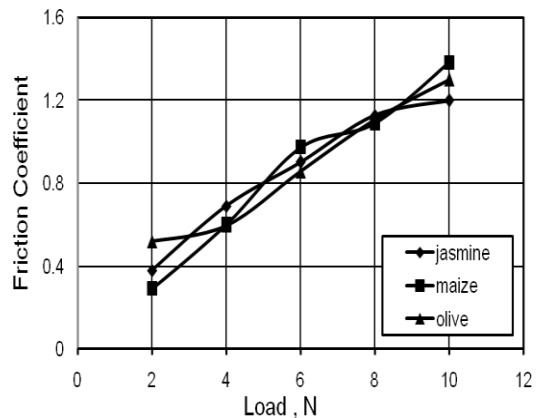

Fig. 2. 8 Friction coefficient at oil lubricated and PE contaminated brass surface under application of magnetic field.

Application of the magnetic field showed further friction decrease, Figs. 2. 7 and 2. 8. This trend might be attributed to the effect of the magnetic field to increase the adhesion of PE particles into the sliding surfaces and to enhance the reorientation of the oil molecules to form thick film protecting the sliding surfaces.

PA 6 particles caused an increase in friction coefficient compared to PE, Figs. 2. 9 and 2. 10. This behaviour can be explained on the basis that PA 6 particles of positive charge adhered into the scratched brass surface not the insert so that the insert edges as well as brass free of PA 6 interacted with each other. It can be concluded that no change was observed for the addition of PA 6 particles.

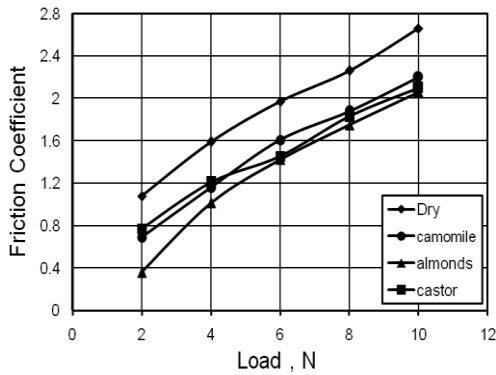

Fig. 2. 9 Friction coefficient at dry, oil lubricated and PA 6 contaminated brass surface.

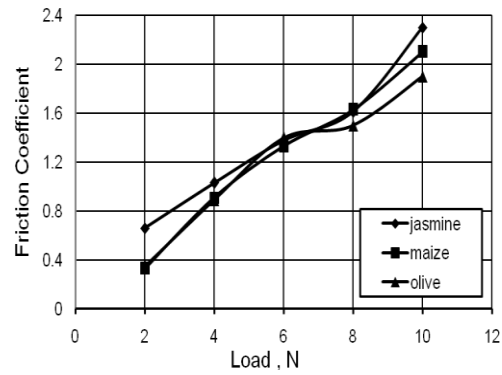

Fig. 2. 10 Friction coefficient at dry, oil lubricated and PA 6 contaminated brass surface.

As the magnetic field was applied, friction coefficient significantly decreased, Figs. 2. 11 and 2. 12. It seems that magnetic field enhanced the reorientation of the oil molecules on the sliding surfaces.

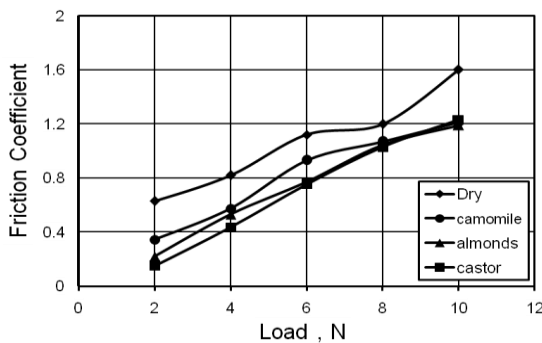

Fig. 2. 11 Friction coefficient at dry, oil lubricated and PA 6 contaminated brass surface under application of magnetic field.

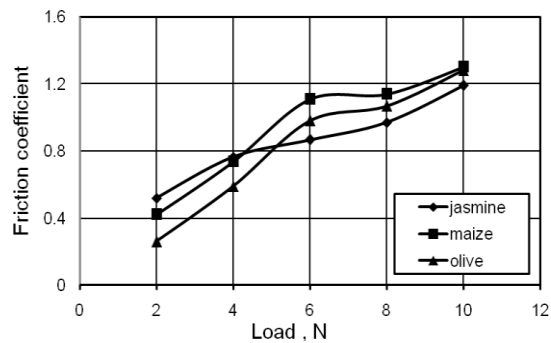

Fig. 2. 12 Friction coefficient at oil lubricated and PA 6 contaminated brass surface under application of magnetic field.

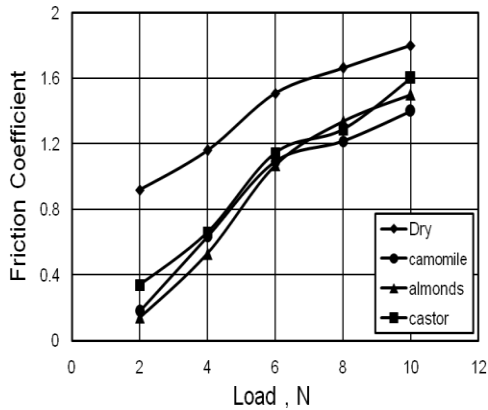

Fig. 2. 13 Friction coefficient at dry, oil lubricated and PMMA contaminated brass surface.

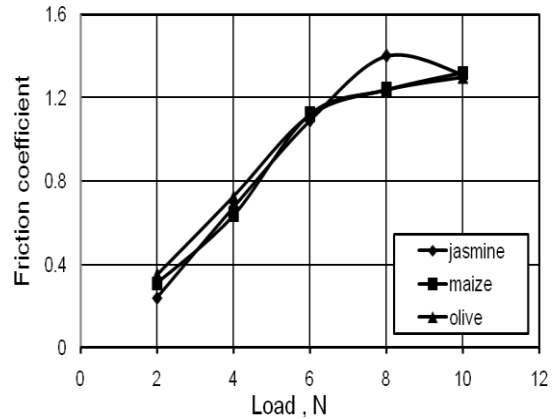

Fig. 2. 14 Friction coefficient at oil lubricated and PMMA contaminated brass surface.

Addition of PMMA particles into the sliding surfaces caused significant reduction in friction coefficient for dry and oil lubricated conditions, Figs. 2. 13 and 2. 14. It seems that the ability of PMMA particles to roll more than to adhere into the sliding surfaces was suitable to protect the surface from the abrasion action of the insert. Besides, the spherical shape of PMMA particles enhanced the rolling tendency.

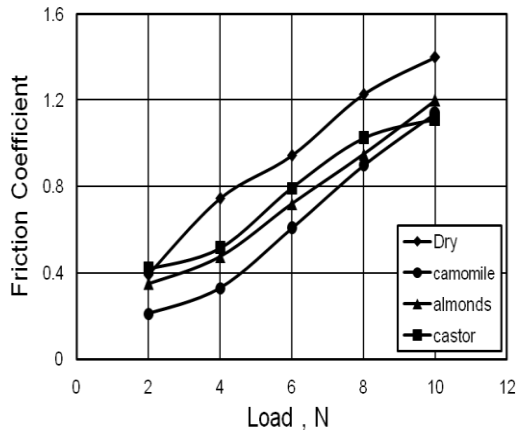

Fig. 2. 15 Friction coefficient at dry, oil lubricated and PMMA contaminated brass surface under application of magnetic field.

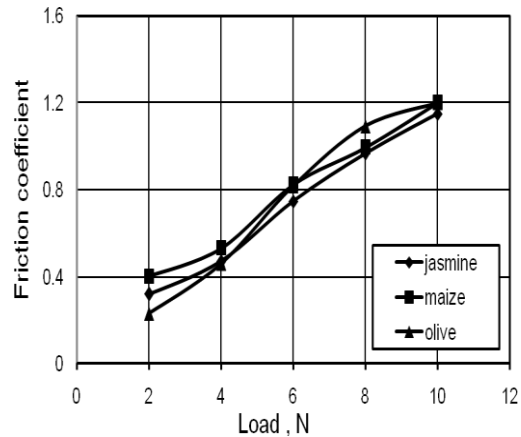

Fig. 2. 16 Friction coefficient at oil lubricated and PMMA contaminated brass surface under application of magnetic field.

Under the action of magnetic field, friction coefficient slightly decreased for dry and oil lubricated sliding. Castor, almonds, chamomile, jasmine, maize, and olive oils displayed lower friction, Figs. 2. 15 and 2. 16. It can be concluded that the addition of PMMA particles had more influence than the magnetic field.

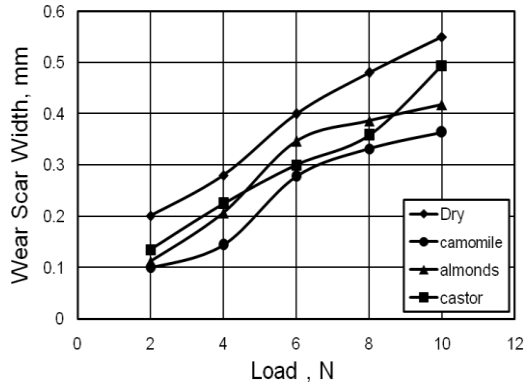

Fig. 2. 17 Wear displayed by dry and oil lubricated brass surface.

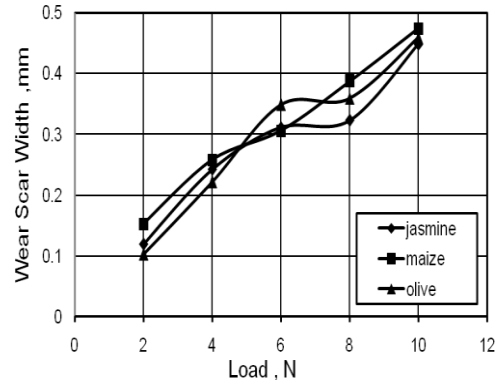

Fig. 2. 18 Wear displayed by oil lubricated brass surface.

Wear displayed by dry and oil lubricated brass surface after the scratch by the steel insert is shown in Figs. 2. 17 and 2. 18. Generally, wear displayed relatively higher values than that observed for steel. Camomile and almonds oil showed the lowest wear values.

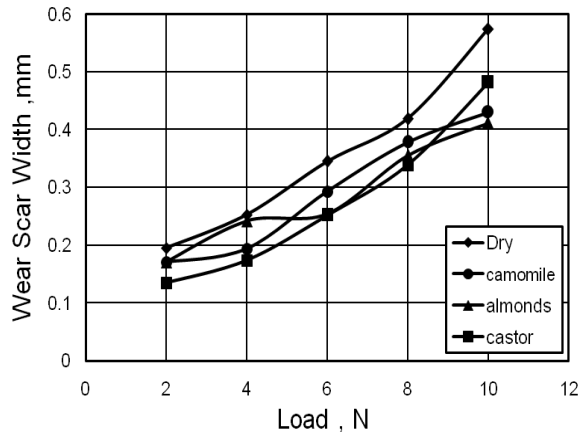

Fig. 2. 19 Wear displayed by dry and oil lubricated brass surface under application of magnetic field.

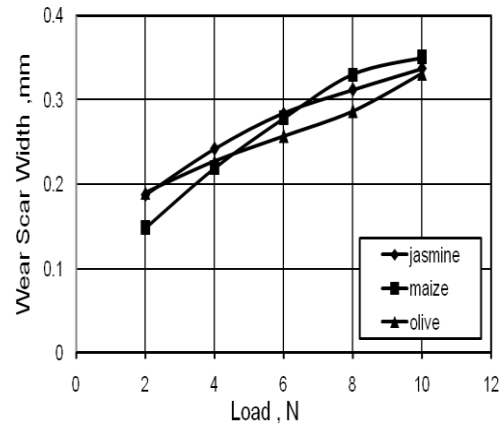

Fig. 2. 20 Wear displayed by oil lubricated brass surface under application of magnetic field.

Application of the magnetic field slightly decreased wear. Olive, jasmine and maize oils displayed the lowest wear values, Figs. 2. 19 and 2. 20. Wear reduction might be attributed to the formation of thick oil film on the sliding surfaces.

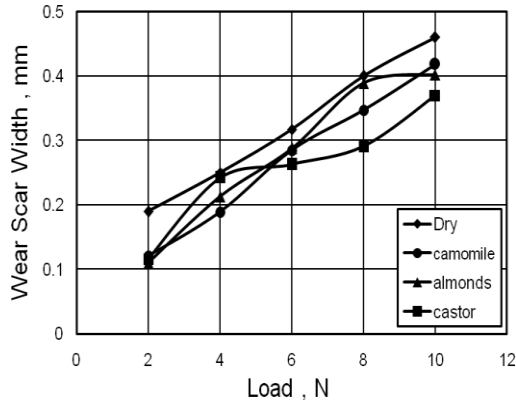

Fig. 2. 21 Wear displayed by dry and oil lubricated and PE contaminated brass surface.

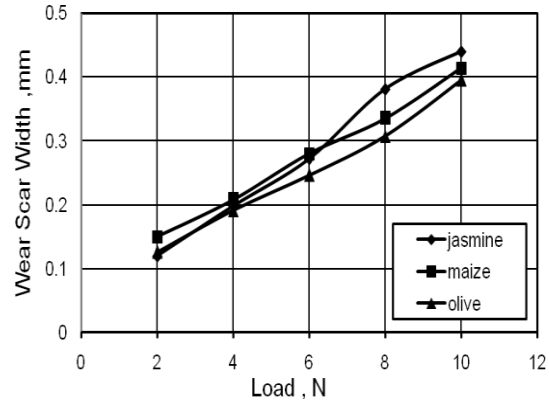

Fig. 2. 22 Wear displayed by oil lubricated and PE contaminated brass surface.

Presence of PE particles on the sliding surfaces slightly decreased wear, Figs. 2. 21 and 2. 22. PE particles of negative charge were adhered into the insert and decreased the cutting action of the insert.

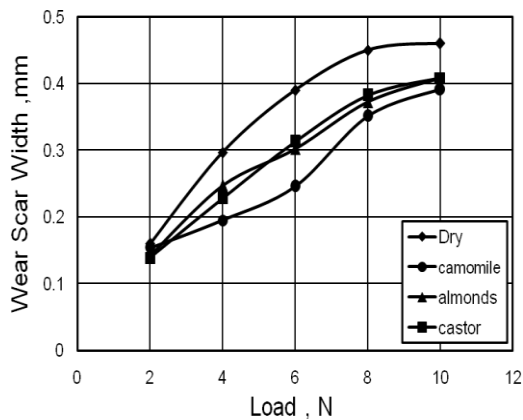

Fig. 1. 23 Wear displayed by dry and oil lubricated and PE contaminated brass surface under application of magnetic field.

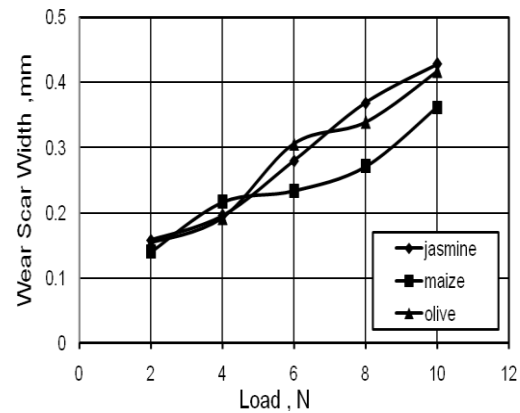

Fig. 1. 24 Wear displayed by oil lubricated and PE contaminated brass surface under application of magnetic field.

Magnetic field slightly decreased the wear for lubricated brass, Figs. 2. 23 and 2. 24. Dry sliding displayed relatively lower values of wear. Castor and maize oils showed good wear resistance. It can be seen that the effect of PE particles were more pronounced than the magnetic field.

Presence of PA 6 particles on the brass surface slightly decreased wear, Figs. 2. 25 and 2. 26. This behaviour could be attributed to the adhesion of PA 6 particles into the insert surface. Further wear decrease was observed as the magnetic field applied on the sliding surfaces, Figs. 2. 27 and 2. 28. It can be seen that values of wear represented lower values than that observed for PE.

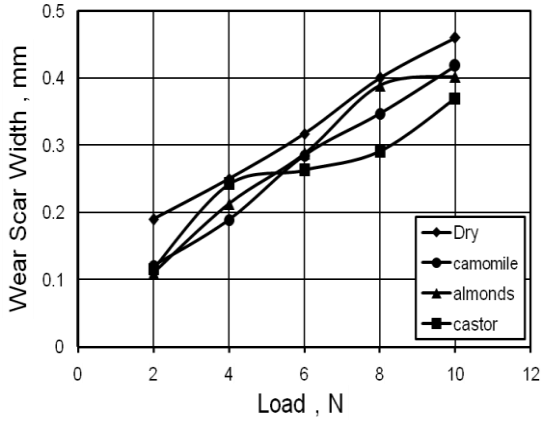

Fig. 1. 25 Wear displayed by dry and oil lubricated and PA 6 contaminated brass surface.

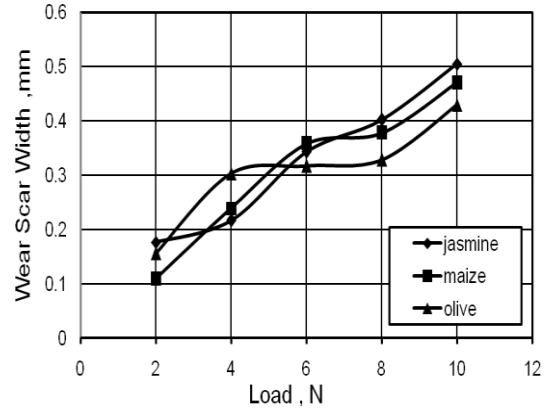

Fig. 1. 26 Wear displayed by oil lubricated and PA 6 contaminated brass surface.

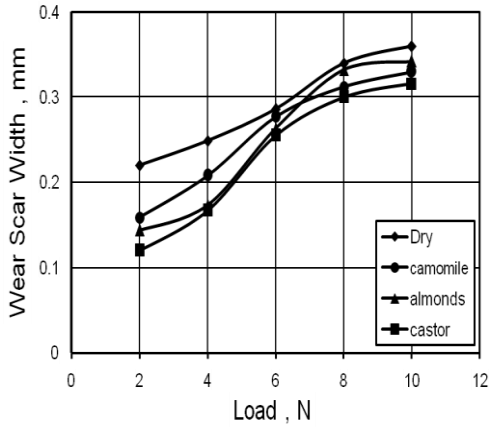

Fig. 1. 27 Wear displayed by dry and oil lubricated and PA 6 contaminated brass surface under application of magnetic field.

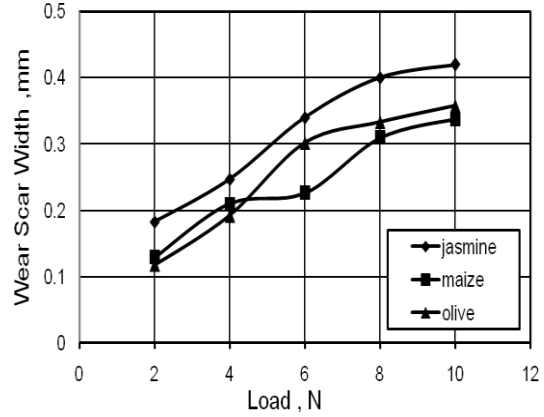

Fig. 1. 28 Wear displayed by oil lubricated and PA 6 contaminated brass surface under application of magnetic field.

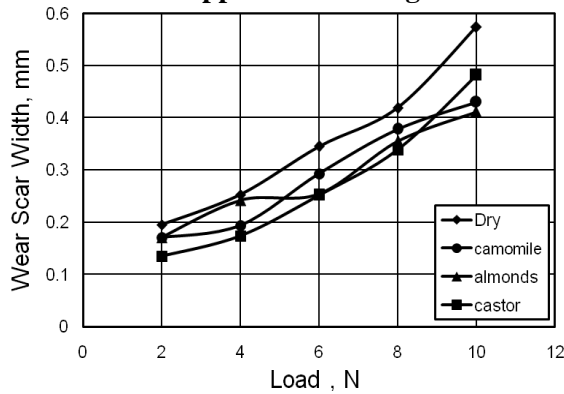

Fig. 1. 29 Wear displayed by dry and oil lubricated and PMMA contaminated brass surface.

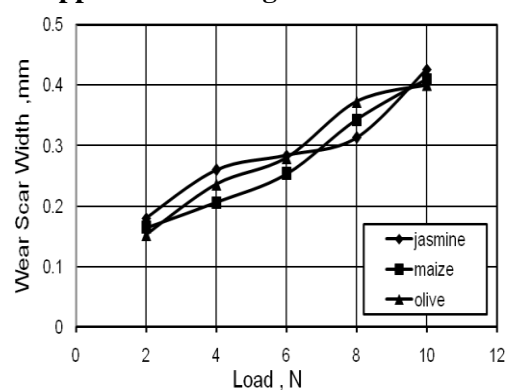

Fig. 1. 30 Wear displayed by oil lubricated and PMMA contaminated brass surface.

Presence of PMMA decreased wear, Figs. 2. 29 and 2. 30. The tendency of the PMMA particles to roll decreased the action of the insert tip to penetrate the brass sheet. The action of the PMMA particles was more pronounced for the oil lubricated surfaces, where jasmine, maize and olive oils displayed the lowest wear.

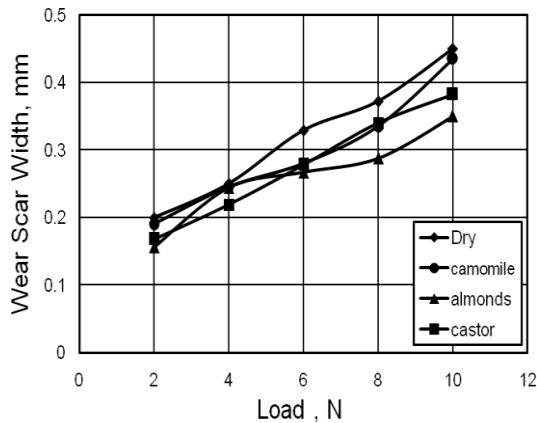

Fig. 2. 31 Wear displayed by dry and oil lubricated and PMMA contaminated brass surface under application of magnetic field.

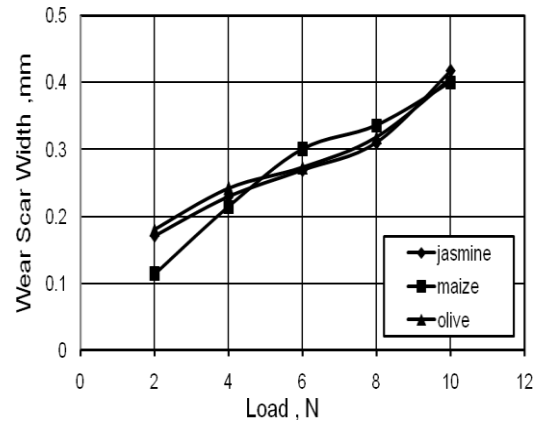

Fig. 2. 32 Wear displayed by oil lubricated and PMMA contaminated brass surface under application of magnetic field.

Application of magnetic field caused significant wear reduction, Figs. 2. 31 and 2. 32. The wear decrease may be attributed to the ability of magnetic field to superimpose an extra attractive force to the PMMA particles to be bonded to the brass and steel surfaces.

CONCLUSIONS

1. Friction coefficient at dry and oil lubricated brass surface displayed higher values than that observed for steel. As the magnetic field was applied, friction coefficient drastically decreased.
2. Polymeric particles caused significant reduction in friction coefficient. Application of the magnetic field showed further friction decrease. Under the action of the magnetic field, friction coefficient slightly decreased for dry and oil lubricated sliding. Castor, almonds, camomile, jasmine, maize, and olive oils displayed lower friction.
3. Wear displayed relatively higher values than that observed for steel. Camomile and almonds oil showed the lowest wear values. Application of the magnetic field slightly decreased wear. Olive, jasmine and maize oils displayed the lowest wear values.
4. Presence of polymeric particles on the sliding surfaces slightly decreased wear. Magnetic field slightly decreased wear. Dry sliding displayed relatively lower values of wear. Castor and maize oils showed good wear resistance.

REFERENCES

1. Zaidi H., Chin K.J., Frene J., "Electrical contact steel/steel in magnetic field: Analysis of surface and subsurface of sliding", *Surface and Coatings Technology* 148, pp. 241 - 250, (2001).
2. F.R.N. Nabarro, *Theory of Dislocations*, Dover Publications, Inc, p. 658, (1987).

3. Negita K., Itou H. and Yakou T., "Electrorheological Effect in Suspension Composed of Starch Powder and Silicone Oil", *Journal of Colloid and Interface Science* 209, pp.251–254, (1999).
4. Hongjun J., Yonggang M., Shizhu W., Hong J., "Effects of external electric fields on frictional behaviors of three kinds of ceramic/metal rubbing couples", *Tribology International* 32, pp. 161–166, (1999).
5. Lavielle L. Electric field effect on the friction of a polyethyleneterpolymer film on a steel substrate. *Wear* 176, pp. 89–93, (1994).
6. Csapo E, Zaidi H, Paulmier D. Friction behavior of a graphite– graphite dynamic electric contact in the present of argon. *Wear* 192, pp. 151–6, (1996).
7. Kimura Y, Nakano K, Kato T, Morishita S. Control of friction coefficient by applying electric fields across liquid crystal boundary films. *Wear* 175, pp. 143 – 9, (1994).
8. Tung SC, Wang SS. In-situ electro-charging for friction reduction and wear resistant film formation. *Tribology Transaction*,34(4) pp.479–88, (1991).
9. Tung SC, Wang SS. Friction reduction from electrochemically deposited films. *Tribology Transaction*,34(1), pp. 23–34. (1991).
10. Nakanishi Y, Murakami T, Higaki H. Effects of electric field on lubricating ability of sodium hyaluronate solution. *Nippon Kikai Gakai Ronbunshu (C Hen)*, 62(598), pp. 2359–66, (1996).
11. Hongjun J, Yonggang M, Shizhu W, Effects of External DC. Electric fields on friction and wear behavior of alumina/brass sliding pairs. *Science in China (series E)*, 41(6), pp. 617–25, (1998).
12. Hongjun J, Yonggang M, Shizhu W, Wong PL. Active control of friction by applying electric fields across boundary films of stearate, *Proceedings of ASIATRIB'98*. Beijing, China, pp. 755–60, (1998).
13. Y. Yamamoto, B. Ono, A. Ura, "Effect of applied voltage on friction and wear characteristics in mixed lubrication", *Lubr. Sci.* 8 pp. 199–207, (1996).
14. A. Takeuchi, Various tribological phenomena in current flow (Part 3): control of running-in by application of electric field, *Jpn. J. Tribol.* 41 pp. 735–744, (1996).
15. T. Katafuchi, Effects of electric current on wear under lubricated conditions, *JSLE* 30 pp. 887–893, (1985).
16. H. Wistuba, The effect of an external electric field on the operation of an aluminum oxide-cast iron sliding contact joint, *Wear* 208, pp. 113 - 117, (1997).
17. Morizur, M. F. and Briant, J., "Modifications of Electron Properties of Friction Surfaces in Boundary Lubrication", C2/4/87, IMechE, (1987).
18. Taylor, C. M., "Engine Tribology", *Tribology Series*, 26, Elsevier, Amsterdam, p. 76, (1993).
19. Bely, V. A., Pinchuk, L. S., Klimovich, A. F. and Guzenkov, S. I., "Tribological Aspects of Electret State Generation in Polymers", *Proceedings of The 5th Int. Congress on Tribology, EUROTRIB 89*, Vol. 2, June 13 - 16, Espo, Finland, pp. 276 - 281, (1989).
20. Ali, W. Y., " Experimental Study of the Potential Generated by Friction of Polymeric Coatings", 4th Conference of the Egyptian Society of Tribology, EGTRIB'95, Jan. 4-5, Cairo, Egypt, (1995).
21. Nakayama, K. and Hashimoto, H., "Triboemission From Various Materials in Atmosphere", *Wear*, 147, pp. 335 - 343, (1991).

22. Fayeulle, S., Berroug, H., Hamzaoui, B. and Treheux, D., "Role of Dielectric Properties in the Tribological Behaviour of Insulators", *Wear*, 162 - 164, pp. 906 - 912, (1993).
23. Ali, W. Y., "Influence of Applied Voltage on Friction and wear of Polymeric Coatings Sliding Against Steel", *Tribologie und Schmierungstechnik*, 43. Jahrgang, March/April 1996, pp. 83 - 87, (1996).
24. Yamamoto, Y., Ono, B. and Ura, A., "Effect of Applied Voltage on Friction and Wear Characteristics in Mixed lubrication", *Proceedings of the VI Int. Congress on Tribology*, Vol. 5 EUROTRIB'93, Budapest, Hungary, pp. 82 - 89, (1993).
25. Nery, H., Zaidi, H., Pan, L. and Paulmier, D., "Influence of Magnetic Field on Steel in Sliding Contact", *Proceedings of the VI Int. Congress on Tribology*, Vol. 5 EUROTRIB'93, Budapest, Hungary, pp. 70 - 75, (1993).
26. Koutkov, A. A., "A Brief Summary of Recent Work on the Friction and Wear of Metals and Polymers under Boundary Conditions", *Wear*, 15, pp. 294-296, (1970).
27. Youssef, M. M., Ezzat, F. M., and Ali, W. Y., "Triboelectrification of Polymeric Materials", *PEDD 6*, *Proceedings of the 6th International Conference on Production Engineering and Design for Development*, Cairo, EGYPT, February 12 – 14, (2002).
28. Youssef, M. M., "Triboelectrification of Metallic and Polymeric Materials" *Bulletin of the Faculty of Engineering, El-Minia University*, Vol. 20, No. 1., July 2001, pp. 31 – 41, (2001).
29. Youssef, M. M., Mahmoud, M. M. and Ali, W. Y., "Friction and Wear of Polymeric Materials Sliding Against Steel", *Journal of the Egyptian Society of Tribology*, Vol. 2, No. 1, April, pp. 18 – 31, 45. *Tribologie-Fachtagung*, 25th – 27th, September 2004 in Göttingen, pp. 9/1 – 9/14, (2004).
30. M. Kalin, J. Vizintin, J. Barriga, K. Vercaemmen, K. Van Acker, A. Arnsek, The effect of doping elements and oil additives on the tribological performance of boundary-lubricated DLC contacts, *Tribol. Lett.* 17 (Nr. 4), pp. 679–688, (2004).
31. U.S. Choi, B.G. Ahn, O.K. Kwon, et al., Tribological behavior of some antiwear additives in vegetable oils, *Tribol. Int.* 30, pp. 677–683, (1997).